

LAHORE UNIVERSITY OF MANAGEMENT SCIENCES
Department of Electrical Engineering

EE240 Circuits I
Quiz 07 - Section 1 (Solutions)

Name: _____

Campus ID: _____

Total Marks: 10

Time Duration: 15 minutes

Question 1 (10 marks)

In the following circuit, the switch SW_1 is closed at $t = 0$. Determine $v_1(0^+)$, $v_2(0^+)$, $v_3(0^+)$, $\frac{dv_1}{dt}(0^+)$, $\frac{dv_3}{dt}(0^+)$ and $\frac{d^2v_3}{dt^2}(0^+)$.

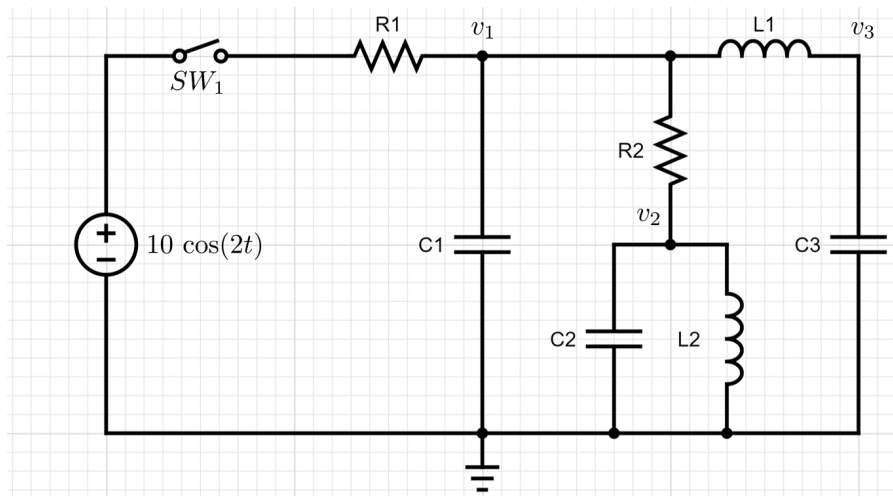

Solutions: Let $v(t) = 10 \cos(2t)$.

Since the capacitors are initially uncharged, $v_1(0^+) = v_2(0^+) = v_3(0^+) = 0$

Furthermore, the current through inductors at $t = 0^+$ is zero.

Network Equations:

$$\text{Node 1 : } \frac{v_1 - v}{R_1} + C_1 \frac{dv_1}{dt} + \frac{v_1 - v_2}{R_2} + \frac{1}{L_1} \int (v_1 - v_3) dt = 0 \quad (1)$$

$$\text{Node 2 : } \frac{v_2 - v_1}{R_1} + C_2 \frac{dv_2}{dt} + \frac{1}{L_2} \int v_2 dt = 0 \quad (2)$$

$$\text{Node 3 : } C_3 \frac{dv_3}{dt} + \frac{1}{L_1} \int (v_3 - v_1) dt = 0 \quad (3)$$

Using equation (1), we obtain

$$\frac{dv_1}{dt}(0^+) = \frac{v(0^+)}{R_1 C_1} = \frac{10}{R_1 C_1}$$

Using equation (3),

$$\frac{dv_3}{dt}(0^+) = 0$$

Taking derivative of equation (3), we have

$$\frac{d^2v_3}{dt^2}(0^+) = 0$$